

# Performance Improvements in Extremum Seeking Control

M. Guay



September 30, 2016, LCCC Process Control Workshop, Lund

- 1 Background
- 2 Perturbation based ESC
  - Basic perturbation based ESC
  - Proportional-integral ESC
- 3 Recursive least-squares approach
  - RLS Proportional integral ESC
- 4 Discrete-time systems
- 5 Distributed network optimization
- 6 Concluding Remarks and Perspective

# Introduction

- Extremum seeking is a real-time optimization technique.

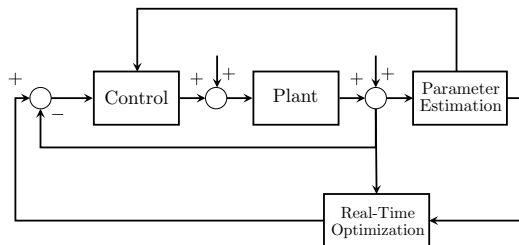

Figure : Basic RTO loop.

- RTO is a supervisory system designed to monitor and improve process performance.
- It uses process data to move the process to operating points that are optimal wrt a meaningful user-defined metric

# Introduction

- In most applications, RTO exploits process models and optimization techniques to compute optimal steady-state operating conditions
  - ▶ Control objectives vs. Optimization objectives
- Success of RTO relies on
  - ▶ the accuracy of the (steady-state) model
  - ▶ robustness of the RTO approach
  - ▶ flexibility of the control system
- In the absence of accurate process descriptions (model-based) RTO yields erratic results

*Successful RTO requires integrated solutions.*

- Extremum Seeking Control (ESC) is a model free technique that relies on minimal assumptions concerning:
  - ▶ the process model
  - ▶ the objective function
  - ▶ the constraints
- ESC only requires the measurement of the objective function and the constraints
- Considerable appeal in practice
  - ▶ Achieves RTO objectives without the need for complex model-based formulations.

- Extremum-seeking control (ESC) has been the subject of considerable research effort over the last decade.
- Mechanism dates back to the 1920s [Leblanc, 1922]
  - ▶ Objective is to drive a system to the optimum of a measured variable of interest [Tan et al., 2010]
- Revived interest in the field was primarily sparked by Krstic and co-workers [Krstic and Wang, 2000]
  - ▶ Provided an elegant proof of the convergence of a standard perturbation based ESC for a general class of nonlinear systems

Basic ESC objectives:

- Given an (unknown) nonlinear dynamical system and (unknown) measured cost function:

$$\dot{x} = f(x, u) \quad (1)$$

$$y = h(x) \quad (2)$$

- The objective is to steer the system to the equilibrium  $x^*$  and  $u^*$  that achieves the minimum value of  $y(= h(x^*))$ .

## Problem Definition

- The objective is to steer the system to the equilibrium  $x^*$  and  $u^*$  that achieves the minimum value of  $y(= h(x^*))$ .
  - ▶ The equilibrium (or steady-state) map is the  $n$  dimensional vector  $\pi(u)$  which is such that:

$$f(\pi(u), u) = 0.$$

- ▶ The equilibrium cost function is given by:

$$y = h(\pi(u)) = \ell(u) \tag{3}$$

- ▶ The problem is to find the minimizer  $u^*$  of  $y = \ell(u^*)$ .



# Problem Definition

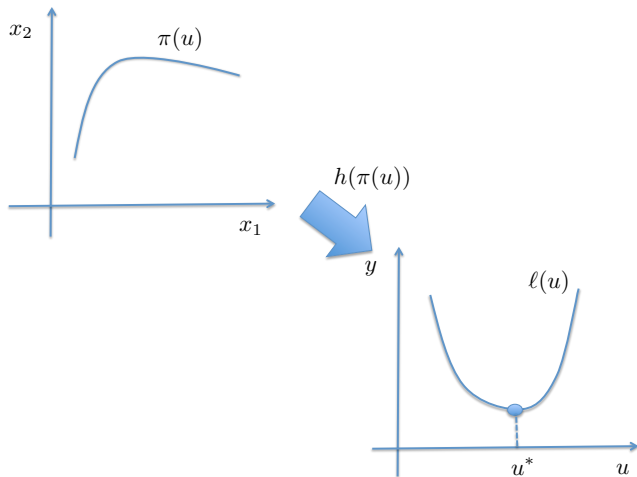

# Basic ESC Loop

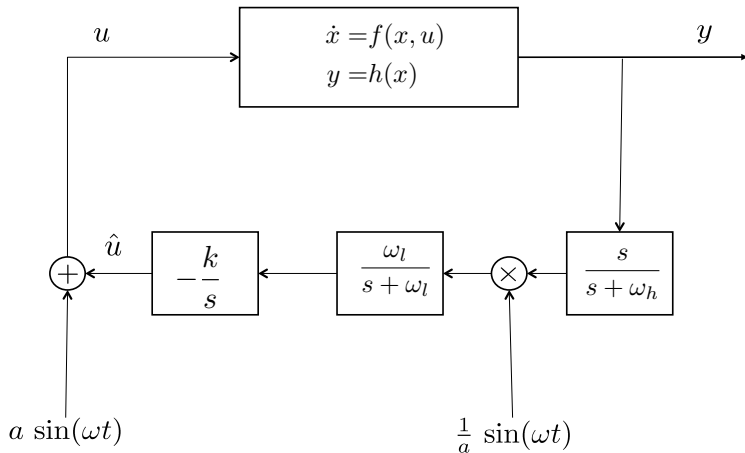

## Basic ESC Loop

- Closed-loop dynamics are:

$$\dot{x} = f(x, \hat{u}(t) + a \sin(\omega t))$$

$$\dot{\hat{u}} = -\omega k \xi$$

$$\dot{\xi} = -\omega \omega_l \xi + \omega \frac{\omega_l}{a} (h(x) - \eta) \sin(\omega t)$$

$$\dot{\eta} = -\omega \omega_h \eta + \omega \omega_h h(x).$$

- Tuning parameters are:
  - ▶  $k$  the adaptation gain
  - ▶  $a$  the dither signal amplitude
  - ▶  $\omega$  the dither signal frequency
  - ▶  $\omega_l$  and  $\omega_h$  the low-pass and high-pass filter parameters

## Basic ESC loop

- The stability analysis [Krstic and Wang, 2000] relies on two components:
  - ① an averaging analysis of the persistently perturbed ESC loop
  - ② a time-scale separation of ESC closed-loop dynamics between the system dynamics and the quasi steady-state extremum-seeking task.
- This is a very powerful and very general result.
- Analysis confirms properties: *small a*, *small  $\omega$* , *small k*.
- Convergence is slow with limited robustness.

# Proportional Integral ESC

Limitations associated with the two time-scale approach to ESC remains problematic.

- Two (or more) time-scale assumption is required to ensure that optimization operates at a quasi steady-state time-scale
- Convergence is very slow.
- Limits applicability in practice.

Improvement in transient performance are possible:

- Standard ESC is an integral controller  $\rightarrow$  Performance limitation
- Add proportional action.

# Proportional Integral ESC

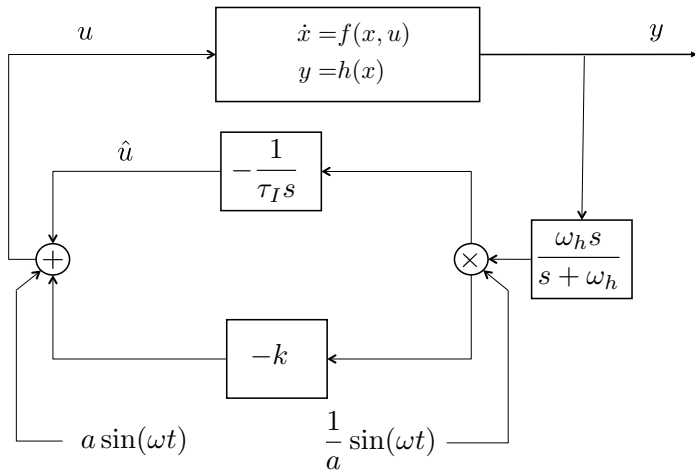

# Proportional Integral ESC

- Proposed PI-ESC algorithm:

$$\dot{x} = f(x) + g(x)u$$

$$\dot{v} = -\omega_h v + y$$

$$\dot{\hat{u}} = -\frac{1}{\tau_I}(-\omega_h^2 v + \omega_h y) \sin(\omega t)$$

$$u = -\frac{k}{a}(-\omega_h^2 v + \omega_h y) \sin(\omega t) + \hat{u} + a \sin(\omega t).$$

- Tuning parameters:

- ▶  $k$  and  $\tau_I$  are the proportional and integral gain
- ▶  $a$  and  $\omega$  are the dither amplitude and frequency
- ▶  $\omega_h (>> \omega)$  is the high-pass filter parameter.

# Proportional Integral ESC

## Theorem 1

Consider the nonlinear closed-loop PIEESC system with cost function  $y = h(x)$ . Let Assumptions 1, 2, 3 and 4 hold. Then

- 1 there exists a  $\tau_I^*$  such that for all  $\tau_I > \tau_I^*$  the trajectories of the nonlinear system converge to an  $\mathcal{O}(1/\omega)$  neighbourhood of the unknown optimum equilibrium,  $x^* = \pi(u^*)$ ,
- 2 there exists  $\omega^* > 0$  such that, for any  $\omega > \omega^*$ , the unknown optimum is a practically stable equilibrium of the PIEESC system with a region of attraction whose size grows with the ratio  $\frac{a}{k}$ ,
- 3  $\|x - x^*\|$  enters an  $\mathcal{O}(\frac{1}{\omega}) + \mathcal{O}(\frac{k}{\omega a}) + \mathcal{O}(\frac{a}{\omega})$  neighbourhood of the origin and  $\|\hat{u} - u^*\|$  enters an  $\mathcal{O}(\frac{1}{\omega}) + \mathcal{O}(\frac{1}{\omega a \tau_I}) + \mathcal{O}(\frac{a}{\tau_I \omega})$  of the origin.



# Proportional Integral ESC

- Proof of theorem demonstrates that:
  - ▶ the proportional action minimizes the impact of the time scale separation
  - ▶ the integral action acts as a standard perturbation based ESC
  - ▶ Combined action guarantees stabilization of the unknown equilibrium
  - ▶ With fast convergence
- Impact of dither signal is inversely proportional to the frequency
- Size of ROA is proportional to  $\frac{a}{k}$ .
- **PIESC acts as a dynamic output feedback nonlinear controller.**

## Example 1

We consider the following dynamical system taken from Guay and Zhang [2003]:

$$\begin{aligned}\dot{x}_1 &= x_1^2 + x_2 + u \\ \dot{x}_2 &= -x_2 + x_1^2\end{aligned}$$

The cost function to be minimized is given by:  $y = -1 - x_1 + x_1^2$ .

- the optimum cost is  $y^* = -1.25$  and occurs at  $u^* = -0.5$ ,  $x_1^* = 0.5$ ,  $x_2^* = 0.25$
- The tuning parameters are chosen as:  $k = 10$ ,  $\tau_I = 0.1$ ,  $a = 10$ ,  $\omega = 100$  with  $\omega_h = 1000$ .
- Outperforms the model-based approach of Guay and Zhang [2003]

# Example 1

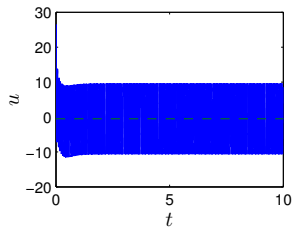
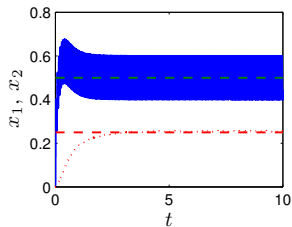
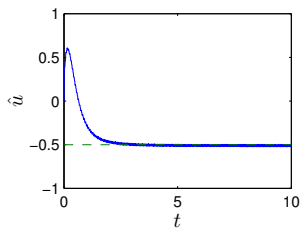
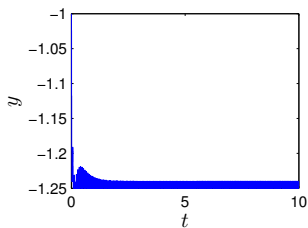

# RLS Proportional Integral ESC

- Parameterize  $\dot{y}$  as:

$$\dot{y} = \theta_0 + \theta_1 u = \phi^T \theta \quad (4)$$

where  $\phi = [1, u^T]^T$  and  $\theta = [\theta_0, \theta_1^T]^T$ .

- $\theta_0$  and  $\theta_1$  are unknown time-varying parameters.
- Proposed PI-ESC given by:

$$u = -k\hat{\theta}_1 + \hat{u} + d(t)$$

$$\dot{\hat{u}} = -\frac{k}{\tau_I} \hat{\theta}_1$$

where

- ▶  $\hat{\theta}_1$  is the estimation of  $\theta_1$ .
- ▶  $k$  is the proportional gain
- ▶  $\tau_I$  is the integral time constant.

## Parameter Estimation

The proposed time-varying parameter estimation scheme consists of an output prediction mechanism.

$$\dot{\hat{y}} = \phi^T \dot{\hat{\theta}} + K e + c^T \dot{\hat{\theta}} \quad (5)$$

$$\dot{c}^T = -K c^T + \phi^T \quad (6)$$

$$\dot{\hat{\eta}} = -K \hat{\eta}. \quad (7)$$

where

- $\hat{\theta}$  are parameter estimates
- $e = y - \hat{y}$  and  $\tilde{\theta} = \theta - \hat{\theta}$
- $K$  is a positive constant to be assigned
- $c \in \mathbb{R}^p$  is the solution of the differential equation:

## Parameter Estimation

The parameter estimation law is given by:

$$\dot{\Sigma}^{-1} = -\Sigma^{-1}cc^T\Sigma^{-1} + k_T\Sigma^{-1} - \delta\Sigma^{-2} \quad (8)$$

with initial condition  $\Sigma^{-1}(t_0) = \frac{1}{\alpha}I$ , and the parameter update law:

$$\dot{\hat{\theta}} = \text{Proj}(\Sigma^{-1}(c(e - \hat{\eta}) - \frac{\delta}{2}\hat{\theta}), \Theta^0), \quad \hat{\theta}(t_0) = \theta^0 \in \Theta^0, \quad (9)$$

where  $\delta$  is a positive constant.  $\text{Proj}\{\phi, \hat{\theta}\}$  denotes a Lipschitz projection operator Krstic et al. [1995] such that

$$-\text{Proj}\{\phi, \hat{\theta}\}^T \tilde{\theta} \leq -\phi^T \tilde{\theta}, \quad (10)$$

$$\hat{\theta}(t_0) \in \Theta^0 \implies \hat{\theta} \in \Theta, \forall t \geq t_0 \quad (11)$$

where  $\Theta \triangleq B(\hat{\theta}, z_\theta)$ ,

# Parameter Estimation

- **Assumption 4:** There exists constants  $\alpha_1 > 0$  and  $T > 0$  such that

$$\int_t^{t+T} c(\tau)c(\tau)^T d\tau \geq \alpha_1 I \quad (12)$$

$\forall t > 0.$

□

## Theorem 1

*Let Assumptions 1 to 4 hold. Consider the extremum-seeking controller and the parameter estimation algorithm. Then there exists tuning parameters  $k$ ,  $k_T$ ,  $K$  and  $\tau_I^*$  such that for all  $\tau_I > \tau_I^*$ . the system converges exponentially to an  $\mathcal{O}(D/\tau_I)$  neighbourhood of the minimizer  $x^*$  of the measured cost function  $y$ .*

## Example 2

Consider the following system

$$\dot{x}_1 = x_2$$

$$\dot{x}_2 = -x_1 - x_2 + u$$

with the following cost function:

$$y = 4 + (x_1 - 1.5)^2 + x_2^2.$$

- Tuning parameters:  $k_T = 20$ ,  $K = 20I$ ,  $k = 0.25$  and  $\tau_I = 0.15$ .
- $d(t) = 0.1 \sin(10t)$ .
- The initial conditions are  $\hat{\theta}(0) = [0, -1]^T$ ,  
 $x_1(0) = x_2(0) = u(0) = 0$ .



## Example 2

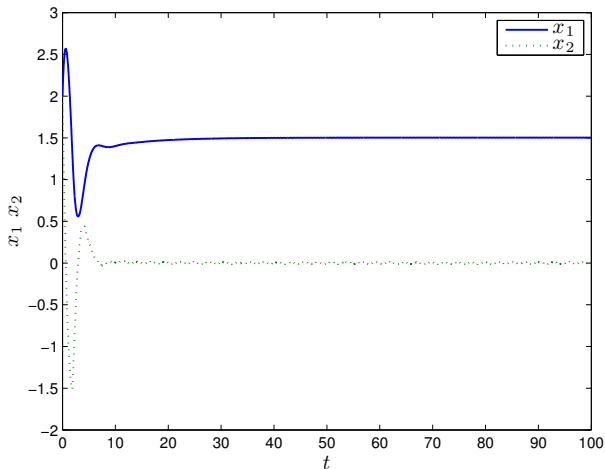

Figure : State trajectories as a function of time.

## Example 2

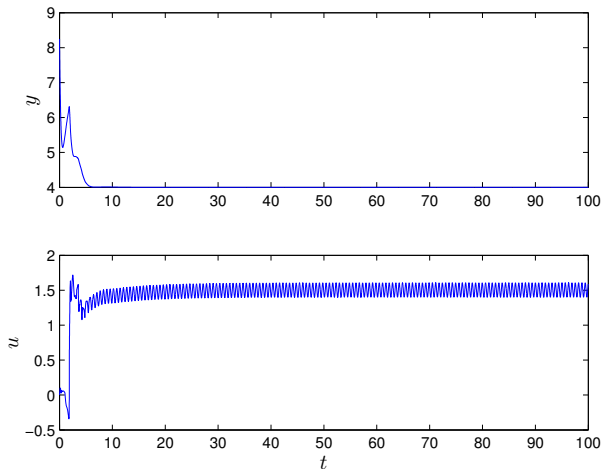

Figure : Input  $u(t)$  and output  $y(t)$ .

- Design of discrete-time ESC systems is not as prevalent:
  - ▶ Discrete-time ESC [Ariyur and Krstic, 2003], [Choi et al., 2002] with application to PID tuning in [Killingsworth and Krstic, 2006].
  - ▶ Adaptive estimation approach [Guay, 2014]
  - ▶ Discrete-time ESC subject to stochastic perturbations [Manzie and Krstic, 2009] and [Liu and Krstic, 2014b].
  - ▶ Approximate parameterizations of the unknown cost function [Ryan and Speyer, 2010].
  - ▶ Analysis of nonlinear-optimization algorithms [Teel and Popovic, 2001].
  - ▶ Global sampling methods [Nesic et al., 2013].

Discrete-time techniques cannot be derived directly from continuous-time techniques.

# Problem Definition

ESC objectives:

- Given an (unknown) nonlinear discrete-time dynamical system and (unknown) measured cost function:

$$x_{k+1} = x_k + f(x_k) + g(x_k)u_k \quad (13)$$

$$y_k = h(x_k) \quad (14)$$

- The objective is to steer the system to the equilibrium  $x^*$  and  $u^*$  that achieves the minimum value of  $y(= h(x^*))$ .

# Proportional Integral ESC

- The cost function dynamics are parameterized as follows:

$$y_{k+1} = y_k + \theta_{0,k} + \theta_{1,k}^T (u_k - \hat{u}_k)$$

where

- $\theta_{0,k}$  and  $\theta_{1,k}$  are the time-varying parameters,  $\theta_{0,k} = \Psi_{0,k}$  and  $\theta_{1,k} = \Psi_{1,k}^T$ .
- Proposed PI-ESC given by:

$$u_k = -k_g \hat{\theta}_{1,k} + \hat{u}_k + d_k$$
$$\hat{u}_{k+1} = \hat{u}_k - \frac{1}{\tau_I} \hat{\theta}_{1,k}$$

where

- ▶  $\hat{\theta}_{1,k}$  is the estimation of  $\theta_{1,k}$ .
- ▶  $k_g$  is the proportional gain
- ▶  $\tau_I$  is the integral time constant.
- ▶  $d_k$  is the dither signal.

# Proportional Integral ESC

- Proposed parameter estimation routine given by:

$$\hat{y}_{k+1} = \hat{y}_k + K(y_k - \hat{y}_k) + \phi_k^T \hat{\theta}_k + \omega_k^T (\hat{\theta}_{1,k+1} - \hat{\theta}_{1,k})$$

$$\Sigma_{k+1} = \alpha \Sigma_k + \omega_k \omega_k^T + \sigma I$$

$$\hat{\theta}_{k+1} = \text{Proj}\{\hat{\theta}_k + (\alpha \Sigma_k + \sigma I)^{-1} \omega_k Q_k (e_k - \hat{\eta}_k), \Theta_k\}$$

$$Q_k = (1 + w_k^T (\alpha \Sigma_k + \sigma I)^{-1} w_k)^{-1}$$

$$\omega_{k+1} = \omega_k - K \omega_k + \phi_k, \quad \hat{\eta}_{k+1} = \hat{\eta}_k - K \hat{\eta}_k$$

- $\phi_k^T = [1, (u_k - \hat{u}_k)^T]^T$ ,  $\hat{\theta}_k = [\hat{\theta}_{0,k}, \hat{\theta}_{1,k}^T]^T$ .
- Proj represents an orthogonal projection onto the surface of the uncertainty set  $\Theta_k = B(\hat{\theta}_c, z_{\hat{\theta}_c})$ .
- Tuning parameters are  $\alpha$ ,  $\sigma$  and  $K$ .

# Proportional Integral ESC

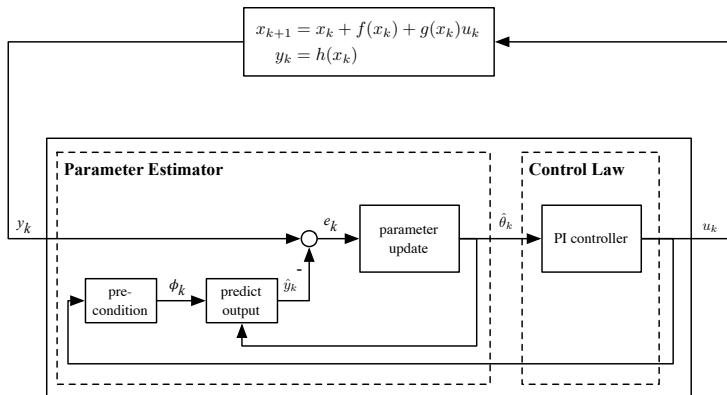

Figure : Schematic representation of the PI-ESC approach.

# Proportional Integral ESC

## Assumption 4 [Goodwin and Sin, 2013]

There exists constants  $\beta_T > 0$  and  $T > 0$  such that

$$\frac{1}{T} \sum_{i=k}^{k+T-1} \omega_i \omega_i^T > \beta_T I, \quad \forall k > T. \quad (15)$$

## Theorem 2

*Consider the nonlinear discrete-time system (13) with cost function (14), the extremum seeking controller and parameter estimation scheme. Let Assumptions 1-6 be fulfilled. Then there exists positive constants  $\alpha$ ,  $K$ ,  $k_g (> k_g^*)$  and  $\tau_I$  such that for every  $\tau_I \geq \tau_I^*$ , the states  $x_k$  and input  $u_k$  of the closed-loop system enter a neighbourhood of the unknown optimum  $(x^*, u^*)$ .*



## Simulation: Example 1

Consider a simple, 1st order, dynamical system:

$$\begin{aligned}x_{k+1} &= 0.8x_k + u_k \\ y_k &= (x_k - 3)^2 + 1\end{aligned}$$

The steady-state optimum occurs at

$$u^* = 0.6$$

$$y^* = 1.$$

A.

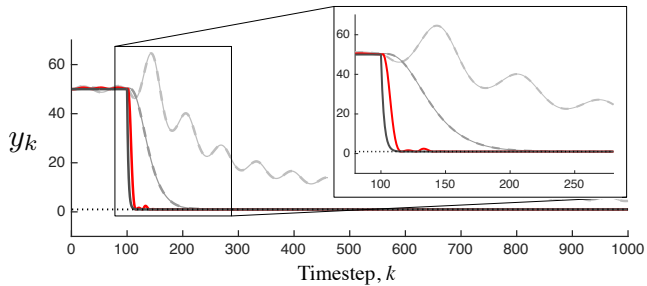
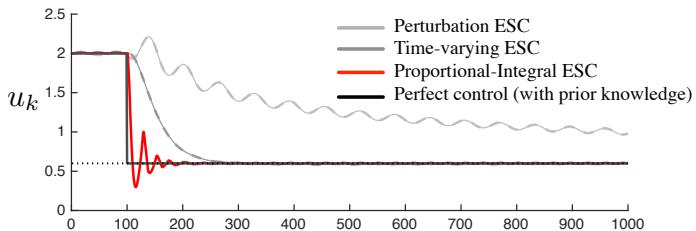

B.

# Distributed Extremum seeking control

Internet network control design

- The discrete-time ESC approach can be generalized for the design of distributed optimization and control of complex unknown networks
- ESC can adjust local actions in the absence of any knowledge about the underlying dynamics and network interactions
- Application to air-based (balloon) internet system design

# Air-based internet

## Why balloons?

- Float in the stratosphere (10–50 km altitude)
- High enough to avoid weather and airplanes
  - ▶ Airplanes typically fly below 15 km altitude
- Low enough for fast connections without lag
  - ▶ Satellites fly in low-earth orbit at around 1200 km altitude
- Float passively to minimize energy costs
- Solar panels help balloons stay up for hundreds of days

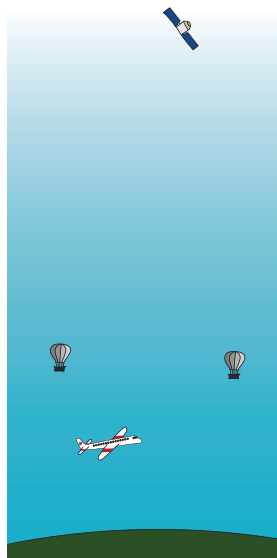

# Modeling balloon dynamics

## Basics

- Each balloon moves in a spherical shell
- Altitude is limited to 10–50km
- Earth's radius is 6371km so we can neglect altitude
- $i^{\text{th}}$  balloon's position can be represented by a point,  $q_i \in \mathbb{S}^2$ .
- Altitude,  $u_i$ , will be used as an input parameter

### Assumption 1

*The balloons move exactly with the wind currents and assume dynamics characterized by local wind patterns.*

# Modeling balloon dynamics

Nonlinear dynamic model

- For each altitude,  $u_i$ , let  $f_{u_i} : \mathbb{R} \times \mathbb{S}^2 \rightarrow \mathbb{T}\mathbb{S}^2$  be a time varying vector field on the sphere. Then the balloon's dynamics are:

$$\dot{q}_i = f_{u_i}(t, q_i) \quad (16)$$

- *For simulation:* An approximate model of  $f_{u_i}$  can be created by interpolating gridded wind data from the NOAA

## Assumption 2

*The time-varying vector fields  $f_{u_i} \in \mathfrak{X}(\mathbb{R}, \mathbb{S}^2)$  are smooth and the map  $u_i \mapsto f_{u_i}$  is smooth*

# Voronoi partitions

## Definition

- Let  $\Gamma_i$  be the region of Earth where users are connected to balloon  $i$
- What should the regions  $\Gamma_i$  look like?
- Define the Voronoi partition by:

$$\Gamma_i = \{q \in \mathbb{S}^2 \mid \mathbb{G}(q, q_i) < \mathbb{G}(q, q_j) \forall j \neq i\} \quad (17)$$

where  $\mathbb{G}(\cdot, \cdot)$  is the round metric on  $\mathbb{S}^2$ .

- Voronoi partitions ensure each user is connected to the nearest balloon

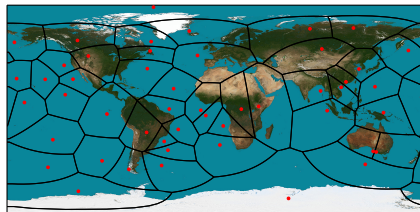

# Controller design

## Control objectives

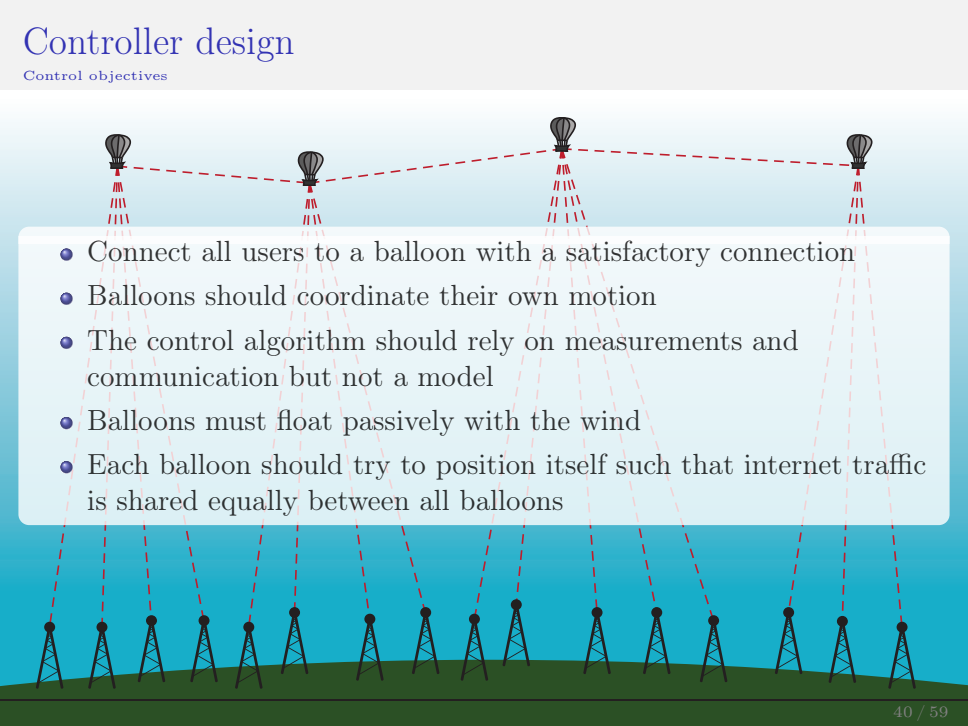
- 
- A diagram illustrating a balloon-based network. Four balloons are positioned in a line across the sky, connected by a dashed red line. Below them, a series of ground-based towers are shown on a green hill. Dashed red lines connect each balloon to a specific tower, representing the network connections. The background is a light blue sky with a green ground line at the bottom.
- Connect all users to a balloon with a satisfactory connection
  - Balloons should coordinate their own motion
  - The control algorithm should rely on measurements and communication but not a model
  - Balloons must float passively with the wind
  - Each balloon should try to position itself such that internet traffic is shared equally between all balloons



# Controller design

## Existing approaches

- Google intends on using “some complex algorithms and lots of computing power” (Official Google Blog [2013])
- Sniderman showed that lots of computing power is unnecessary (Sniderman et al. [2015])
  - ▶ Uses a geometric, block-circulant approach
  - ▶ Algorithms rely on a linear model of wind currents
  - ▶ Simulations only performed on a circle and do not generalize to a sphere
- Can we solve control a non-linear 2-dimensional system without lots of computing power?

# Controller design

Distributed architecture

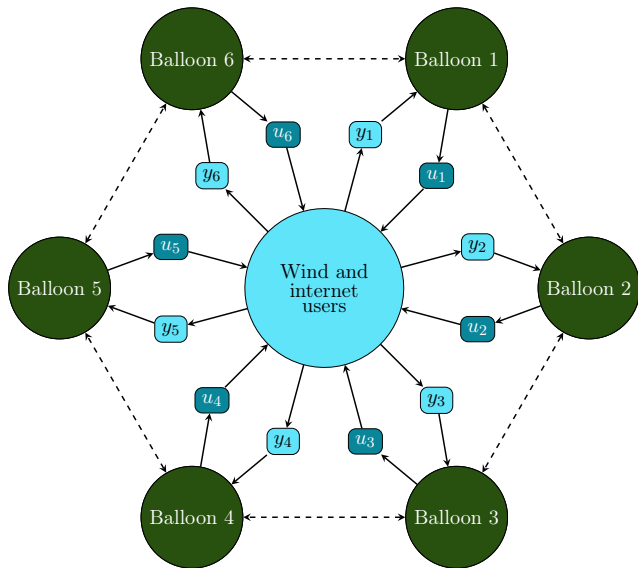

# Controller design

Distributed architecture as seen by one balloon

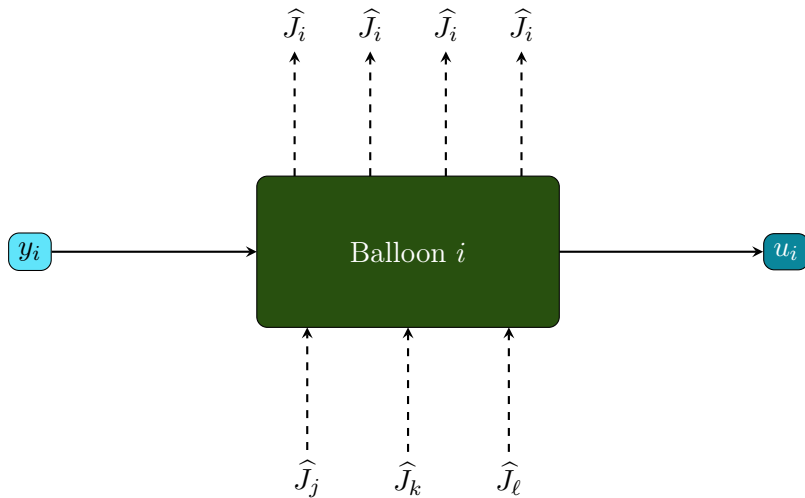

# Controller design

## Consensus estimation

Each balloon measures  $y_i$  and estimates  $\frac{1}{p}J$  by a consensus algorithm

$$\begin{aligned} \begin{bmatrix} \hat{\mathbf{J}}[k+1] - \hat{\mathbf{J}}[k] \\ \boldsymbol{\rho}[k+1] - \boldsymbol{\rho}[k] \end{bmatrix} &= \begin{bmatrix} -\kappa_P \mathbf{I} - \kappa_I \mathbf{L} & -\mathbf{I} \\ \kappa_P \kappa_I \mathbf{L} & \mathbf{0} \end{bmatrix} \begin{bmatrix} \hat{\mathbf{J}}[k] \\ \boldsymbol{\rho}[k] \end{bmatrix} \Delta t \\ &+ \begin{bmatrix} \kappa_P \mathbf{I} \\ \mathbf{0} \end{bmatrix} \mathbf{y}[k] \Delta t + \begin{bmatrix} \mathbf{I} \\ \mathbf{0} \end{bmatrix} \Delta \mathbf{y}[k] \end{aligned} \quad (18)$$

Example (Laplacian matrix)

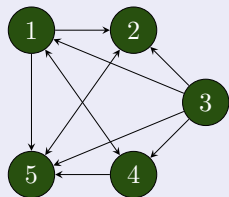

$$\mathbf{L} = \begin{bmatrix} 3 & -1 & 0 & -1 & -1 \\ 0 & 1 & 0 & 0 & -1 \\ -1 & -1 & 4 & -1 & -1 \\ -1 & 0 & 0 & 2 & -1 \\ 0 & -1 & 0 & 0 & 1 \end{bmatrix}$$

# Controller design

## Extremum seeking control (ESC)

- The objective of ESC is to minimize a measured cost
- Balloons estimate the gradient of the  $\hat{J}_i$  with respect to  $u_i$  and move in that direction
- We will use the PI form of ESC:

$$u_i[k] = -k_g \hat{\theta}_{1,i}[k] + \hat{u}_i[k] + d_i[k] \quad (19)$$

$$\hat{u}_i[k+1] = \hat{u}_i[k] - \frac{1}{\tau_I} \hat{\theta}_{1,i}[k] \quad (20)$$

- $\hat{\theta}_{1,i}$  is the gradient estimate,  $k_g$  and  $\tau_I$  are tuning parameters, and  $d_i$  is a dither signal
- Dither signals must all have different frequencies

- The total cost dynamics can be parameterized as:

$$\frac{1}{p} \Delta J[k+1] = \theta_{0,i}[k] + \theta_{1,i}[k] u_i[k] = \boldsymbol{\theta}_i^\top[k] \boldsymbol{\phi}_i[k] \quad (21)$$

- The parameter vector,  $\boldsymbol{\theta}_i$ , can be estimated using a variation of recursive least squares Adetola and Guay [2008]:

$$\boldsymbol{\Sigma}_i[k+1] = \alpha \boldsymbol{\Sigma}_i[k] + \mathbf{w}_i[k] \mathbf{w}_i^\top[k] \quad (22)$$

$$\hat{\boldsymbol{\theta}}_i[k+1] = \text{Proj}_{\gamma_\theta} \left( \hat{\boldsymbol{\theta}}_i[k] + \frac{\boldsymbol{\Sigma}_i^{-1}[k] \mathbf{w}_i[k] (e_i[k] - \hat{\eta}[k])}{\alpha + \mathbf{w}_i^\top[k] \boldsymbol{\Sigma}_i^{-1}[k] \mathbf{w}_i[k]} \right) \quad (23)$$

# Controller design

Single balloon block diagram

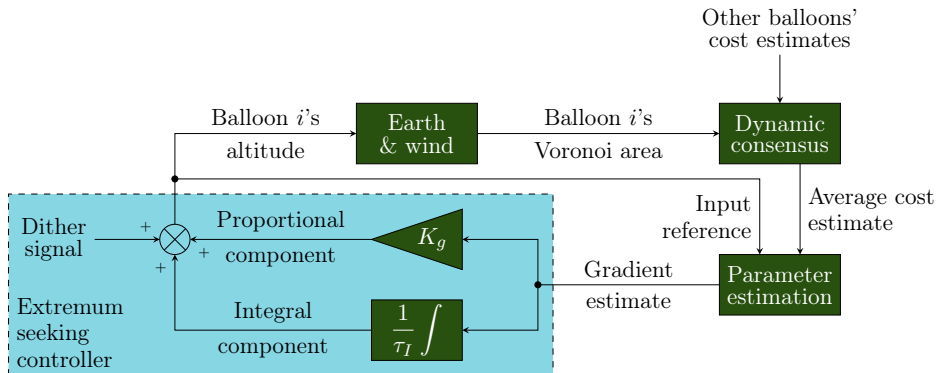

# Simulation results

## Overview

- 1200 balloons floating between 10 kPa and 1 kPa (15–26 km altitude)
- Wind model is an interpolation of wind data on March 8, 2016 at 17:00 UTC from the NOAA National Oceanic and Atmospheric Administration [2016]
- Cost function depends on Voronoi area,  $A_i$ , and distance from centroid,  $q_{c,i} \in \Gamma_i$

$$y_i = \left( A_i - \frac{A_t}{p} \right)^2 + \mathbb{G}(q_i, q_{c,i})^2 \quad (24)$$

- Each balloon communicates with its Delaunay-neighbours and implements identical discrete-time distributed ESC

$\Delta t$	$\kappa_P$	$\kappa_I$	$K$	$\alpha$	$\tau_I$	$K_g$	$D$	$\gamma_\theta$
0.1 h	1	0.5	0.8	0.8	10	1	0.1	1



# Simulation results

## Launch sites

- Many balloons must all start at one of several launch sites
- For simulation, we have chosen 12 large cities around the world as launch sites

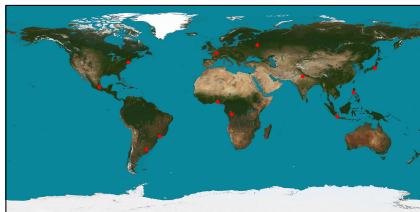

City	Country
New York	USA
Mexico City	Mexico
São Paulo	Brazil
Buenos Aires	Argentina
Paris	France
Moscow	Russia
Lagos	Nigeria
Kinshasa	DR Congo
Tokyo	Japan
Delhi	India
Jakarta	Indonesia
Manila	Philippines

# Simulation results

Balloons without controllers launched from cities

# Simulation results

ESC balloons launched from cities

# Simulation results

Cost function trajectories for balloons launched from cities

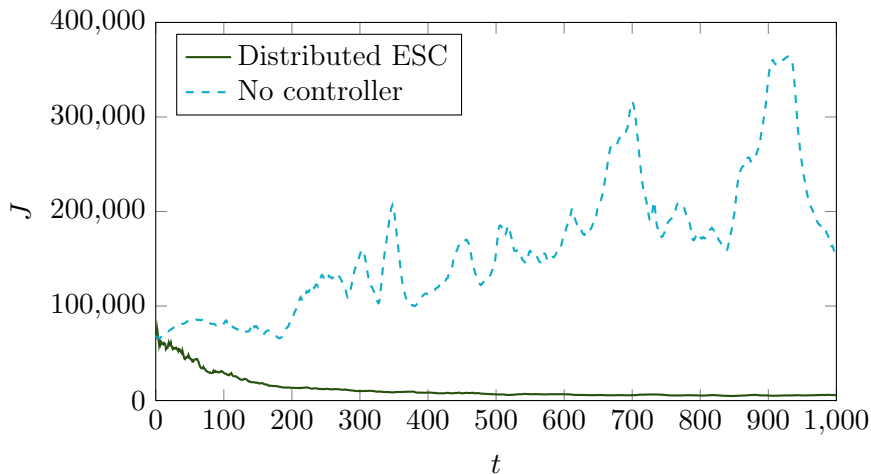

## Concluding Remarks

- ESC can be used to solve of number of problems where:
  - ▶ Exact mathematical nature of the input-output dynamics are unknown
  - ▶ Cost function can be measured or inferred
- Useful for the development of a wealth of new tools in PSE
  - ▶ Feedback stabilization
  - ▶ Observer design
  - ▶ Large scale system optimization
  - ▶ Systematic design of RTO systems

- Beyond existing techniques there are a wealth of new tools that are emerging:
  - ▶ ESC-based MPC
  - ▶ Machine Learning
  - ▶ Large optimization on clouds, etc...
- It is an adaptive, robust, real-time optimization technique with strong potential in many areas:
  - ▶ Automotive
  - ▶ Building Systems Management
  - ▶ Petroleum Production Technologies
  - ▶ Industrial energy management

# Acknowledgements

The support of NSERC, OCE, Queen's University, Mitsubishi Electric Research Laboratory, Johnson Controls and Praxair is gratefully acknowledged.

Thank you.



# Bibliography I

- V. Adetola and M. Guay. Finite-time parameter estimation in adaptive control of nonlinear systems. *IEEE Transactions on Automatic Control*, 53(3):807–811, 2008.
- Kartik B Ariyur and Miroslav Krstic. *Real-time optimization by extremum-seeking control*. Wiley-Interscience, 2003.
- Khalid Tourkey Atta, Andreas Johansson, and Thomas Gustafsson. Extremum seeking control based on phasor estimation. *Systems & Control Letters*, 85:37–45, 2015.
- J.-Y. Choi, M. Krstic, K.B. Ariyur, and J.S. Lee. Extremum seeking control for discrete-time systems. *IEEE Trans. Autom. Contr.*, 47(2):318–323, 2002. ISSN 0018-9286. doi: 10.1109/9.983370.
- A. Ghaffari, M. Krstic, and D. Nesic. Multivariable newton-based extremum seeking. *Automatica*, 48(8):1759–1767, 2012.
- G.C. Goodwin and K.S. Sin. *Adaptive Filtering Prediction and Control*. Dover Publications, Incorporated, 2013. ISBN 9780486137728. URL [http://books.google.ca/books?id=0\\_m9j\\_YM91EC](http://books.google.ca/books?id=0_m9j_YM91EC).
- M Guay and T. Zhang. Adaptive extremum seeking control of nonlinear dynamic systems with parametric uncertainties. *Automatica*, 39:1283–1293, 2003.
- Martin Guay. A time-varying extremum-seeking control approach for discrete-time systems. *Journal of Process Control*, 24(3):98–112, 2014.
- Nick J Killingsworth and Miroslav Krstic. Pid tuning using extremum seeking: online, model-free performance optimization. *Control Systems, IEEE*, 26(1):70–79, 2006.
- M Krstic and H.H. Wang. Stability of extremum seeking feedback for general dynamic systems. *Automatica*, 36(4):595–601, 2000.
- M. Krstic, I. Kanellakopoulos, and P. Kokotovic. *Nonlinear and Adaptive Control Design*. Wiley: Toronto, 1995.
- M Leblanc. Sur l'électrification des chemins de fer au moyen de courants alternatifs de fréquence élevée. *Revue Générale de l'Electricité*, 1922.
- Wei Lin. Further results on global stabilization of discrete nonlinear systems. *Systems & Control Letters*, 29(1):51–59, 1996.

# Bibliography II

- Shu-Jun Liu and Miroslav Krstic. Newton-based stochastic extremum seeking. *Automatica*, 50(3):952 – 961, 2014a. ISSN 0005-1098. doi: <http://dx.doi.org/10.1016/j.automatica.2013.12.023>. URL <http://www.sciencedirect.com/science/article/pii/S0005109813005827>.
- Shu-Jun Liu and Miroslav Krstic. Discrete-time stochastic extremum seeking. In *Proc. IFAC World Congress*, volume 19, pages 3274–3279, 2014b.
- C. Manzie and M. Krstic. Extremum seeking with stochastic perturbations. *IEEE Trans. Autom. Contr.*, 54(3):580–585, 2009.
- William H Moase and Chris Manzie. Fast extremum-seeking for wiener–hammerstein plants. *Automatica*, 48(10):2433–2443, 2012.
- William H Moase, Chris Manzie, and Michael J Brear. Newton-like extremum-seeking for the control of thermoacoustic instability. *IEEE Trans. Autom. Contr.*, 55(9):2094–2105, 2010.
- National Oceanic and Atmospheric Administration. NOAA operation model archive and distribution system, 2016. URL <http://nomads.ncep.noaa.gov/>.
- D. Netic, T. Nguyen, Y. Tan, and C. Manzie. A non-gradient approach to global extremum seeking: An adaptation of the shubert algorithm. *Automatica*, 49(3):809 – 815, 2013. ISSN 0005-1098. doi: 10.1016/j.automatica.2012.12.004. URL <http://www.sciencedirect.com/science/article/pii/S0005109812006036>.
- Official Google Blog. Introducing project loon: Balloon-powered internet access, 2013. URL <http://googleblog.blogspot.ca/2013/06/introducing-project-loon.html>.
- Robert J Renka. Algorithm 772: STRIPACK: Delaunay triangulation and voronoi diagram on the surface of a sphere. *ACM Transactions on Mathematical Software (TOMS)*, 23(3):416–434, 1997.
- John J Ryan and Jason L Speyer. Peak-seeking control using gradient and hessian estimates. In *American Control Conference (ACC), 2010*, pages 611–616. IEEE, 2010.
- Adam C. Sniderman, Mireille E. Broucke, and Gabriele M. T. D’Eleuterio. Formation control of balloons: A block circulant approach. In *American Control Conference (ACC), 2015*, pages 1463–1468. IEEE, 2015.

# Bibliography III

- Y. Tan, D. Nesic, and I. Mareels. On non-local stability properties of extremum seeking control. *Automatica*, 42(6):889 – 903, 2006. ISSN 0005-1098. doi: 10.1016/j.automatica.2006.01.014.
- Y. Tan, W.H. Moase, C. Manzie, D. Nesic and, and I.M.Y. Mareels. Extremum seeking from 1922 to 2010. In *29th Chinese Control Conference (CCC)*, pages 14 –26, july 2010.
- Andrew R Teel and Dobrivoje Popovic. Solving smooth and nonsmooth multivariable extremum seeking problems by the methods of nonlinear programming. In *Proceedings of the 2001 American Control Conference*, volume 3, pages 2394–2399. IEEE, 2001.
- Isaac Vandermeulen, Martin Guay, and P. James McLellan. Discrete-time distributed extremum-seeking control over networks with unstable dynamics. In *10th IFAC Symposium on Nonlinear Control Systems (NOLCOS)*. IFAC, 2016.